

SECTIONAL ENTERTAINMENT CENTER

This contemporary project was built with pocket hole joinery — a “new” technique that required some clever cover-ups.



It's easy to see how practical this project is. The top is a large, solid wood panel that will hold a fairly good-sized TV, and inside there's plenty of storage space for all of your home entertainment components. Even the back has been carefully designed to provide room for organizing cables.

Plus, there are also smaller side cabinets that can be built and set next to the main TV cabinet, as shown in the inset photo. Or to give the components a little more protection, you can build a pair of inset, glass-paneled doors ([page 8](#)).

But it's what you *can't* see that I'm excited about. That's because this project was built almost exclusively with pocket hole screws, refer to the detail on the [next page](#).

This has been my first experience with pocket hole joinery, and I wanted to see what could be built with it. But since this project is an “open” design, I didn't want to have any pocket holes showing. This meant coming up with a number of creative solutions for covering them up. But the final result was worth it — not a pocket hole in sight.



▲ Build a set of matching side cabinets that can be set right next to the main TV case or can “stand alone.” To see this side cabinet in a different light, turn to [page 9](#).

Construction Details

OVERALL DIMENSIONS:
42"W x 24"D x 28"H

NOTE:
Optional side cabinet shown on page 9,
Optional doors for main case on page 8

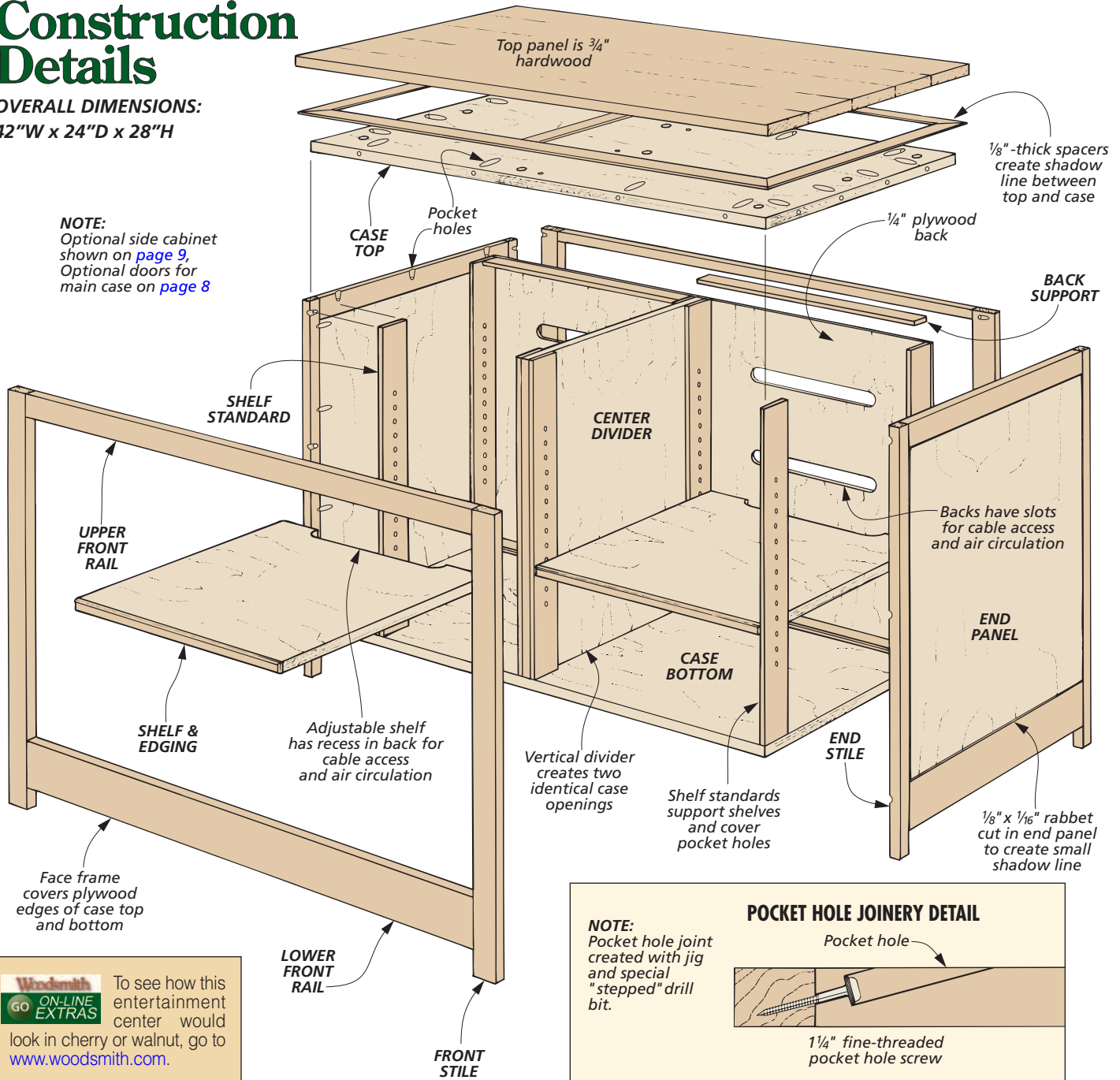

Woodsmith
GO ON-LINE EXTRAS

To see how this entertainment center would look in cherry or walnut, go to www.woodsmith.com.

MATERIALS & SUPPLIES

- | | | | | |
|--------------------------------|--|------------------------------|--|--|
| A End Panels (2) | $\frac{3}{4}$ ply. - 20 $\frac{1}{2}$ x 21 $\frac{1}{8}$ | L Lower Back Rail (1) | $\frac{3}{4}$ x 6 - 38 $\frac{1}{2}$ | • (1 pkg.) #8 x 1 $\frac{1}{4}$ " Pocket Hole Screws |
| B Upr. End Rails (2) | $\frac{3}{4}$ x 1 $\frac{1}{2}$ - 20 $\frac{1}{2}$ | M Shelf Standards (8) | $\frac{3}{8}$ x 2 $\frac{1}{2}$ - 21 $\frac{7}{8}$ | • (6) #8 x 2" Fh Woodscrews |
| C Lwr. End Rails (2) | $\frac{3}{4}$ x 3 - 20 $\frac{1}{2}$ | N Back Supports (4) | $\frac{3}{8}$ x 1 $\frac{1}{2}$ - 19 $\frac{1}{8}$ | • (16) Spoon-Style Shelf Supports |
| D End Stiles (4) | $\frac{3}{4}$ x 1 - 27 $\frac{1}{8}$ | O Back Panels (2) | $\frac{1}{4}$ ply. - 20 $\frac{1}{4}$ x 21 $\frac{7}{8}$ | • (9) #8 x 1 $\frac{1}{4}$ " Rh Woodscrews |
| E Case Top/Btm. (2) | $\frac{3}{4}$ ply. - 22 $\frac{1}{2}$ x 40 $\frac{1}{2}$ | P Shelves (4) | $\frac{3}{4}$ ply. - 19 x 19 | • (9) #8 Flat Washers |
| F Center Divider (1) | $\frac{3}{4}$ ply. - 19 $\frac{1}{4}$ x 21 $\frac{7}{8}$ | Q Shelf Edging (4) | $\frac{3}{4}$ x $\frac{1}{4}$ - 19 | • (2) $\frac{1}{8}$ " Glass (15 $\frac{7}{8}$ " x 17 $\frac{11}{16}$ ")* |
| G Divider Edging (1) | $\frac{3}{4}$ x $\frac{1}{4}$ - 21 $\frac{7}{8}$ | R Top Spacers | $\frac{1}{8}$ x 1 $\frac{1}{2}$ - 180 rgh. | • (1 pkg.) $\frac{1}{2}$ "-long Brads* |
| H Front/Back Stiles (4) | $\frac{3}{4}$ x 1 $\frac{3}{4}$ - 27 $\frac{1}{8}$ | S Top Panel (1) | $\frac{3}{4}$ x 24 - 42 | • (2 pr.) 2" x 1 $\frac{9}{16}$ " Nickel Hinges* |
| I Upper Front Rail (1) | $\frac{3}{4}$ x 1 $\frac{1}{2}$ - 38 $\frac{1}{2}$ | T Door Stiles (4)* | $\frac{3}{4}$ x 2 - 21 | • (2) 96mm Stainless-Steel Pulls* |
| J Lower Front Rail (1) | $\frac{3}{4}$ x 3 - 38 $\frac{1}{2}$ | U Door Rails (4)* | $\frac{3}{4}$ x 2 - 15 $\frac{15}{16}$ | • (2) Magnetic Catches & Strikes* |
| K Upper Back Rail (1) | $\frac{3}{4}$ x $\frac{3}{4}$ - 38 $\frac{1}{2}$ | V Glass Stop* | $\frac{1}{4}$ x $\frac{1}{4}$ - 140 rgh. | |
- * Required for the optional doors

▲ A small rabbet is all it takes to add an interesting shadow line to a frame and panel assembly.

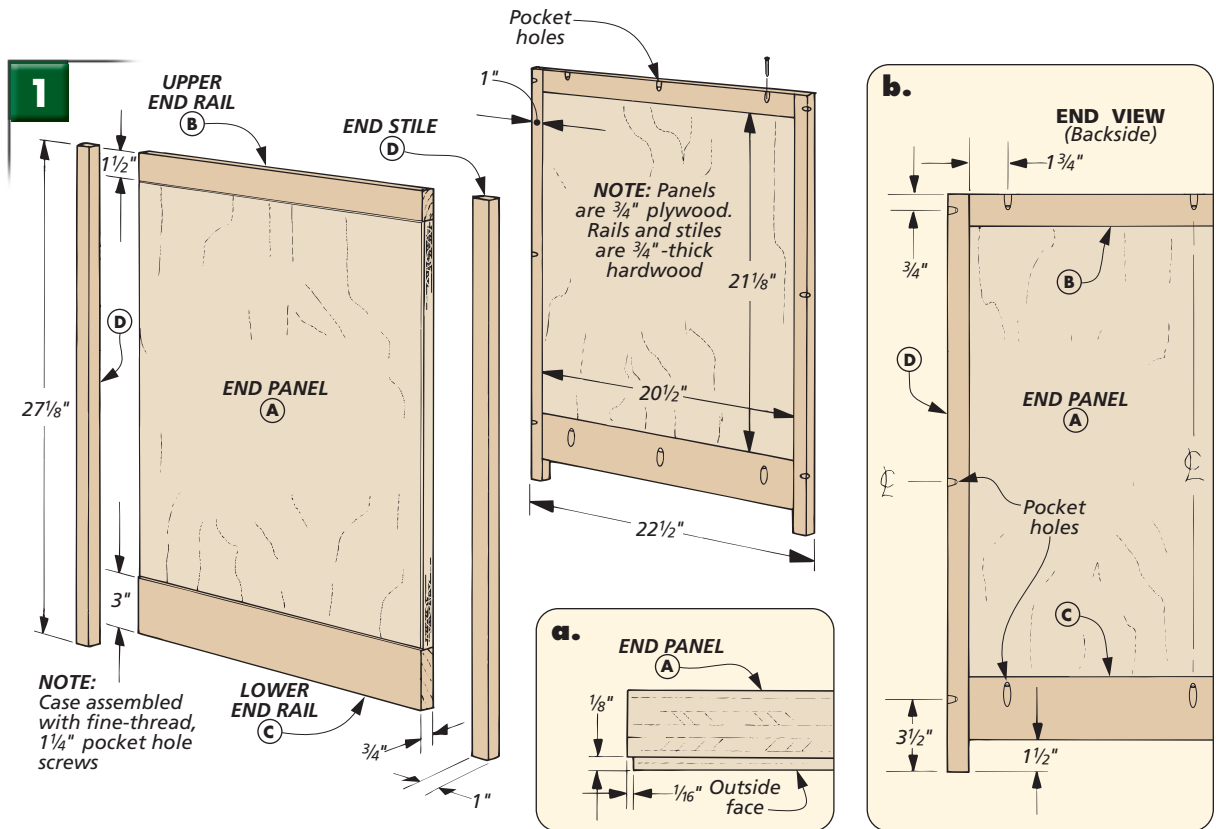

Case Construction

The parts of this entertainment center are fairly typical for case construction. At each end there are frame and panel assemblies, and these are connected with top and bottom panels. Then to create the two openings, a vertical center divider will be added.

What's unique here is that almost the entire case is built using a pocket hole jig and screws. The nice thing is that all the pieces are butt jointed together, so there aren't any dadoes, grooves, or other joints to cut. On the other hand, I found that

this lack of traditional joinery meant that I needed a few "helpers" when it was time to assemble the case. But more on that later.

END PANELS. As with many cases, the first thing to work on are the end assemblies (Fig. 1). But with pocket screws the sequence is a bit different. Instead of starting with the frames, I cut the 3/4" plywood *end panels (A)* to size first.

When frame and panel pieces are the same thickness (as they will be here), it's pretty tough to get them

flush all the way around the panel. I sidestepped the problem by creating a shadow line that accents the panel and hides the joint lines, as shown in the margin photo at left. This is easy to do — just cut a tiny rabbet around each panel (Fig. 1a).

RAILS & STILES. With the rabbets cut on the panels, the rails and stiles can be added to create the frame around the panel (Fig. 1). I started with the *upper (B)* and *lower end rails (C)* since they're cut to length to match the width of this panel.

When attaching the rails to the panels, the pocket holes could have been drilled in either the panels or the rails. As you can see in Fig. 1, I drilled them in the rails. This meant that the holes in the upper rails were drilled partially into their edges, but this method is better because these holes will end up neatly hidden by the top and bottom panels later on.

I should also note two things here before going on. One is that while in most situations the locations of the pocket holes aren't critical, I've included them here because there are so many screws used to build this project (Fig. 1b). This way, you'll be sure to avoid drilling into a neighboring pocket hole (or screw).

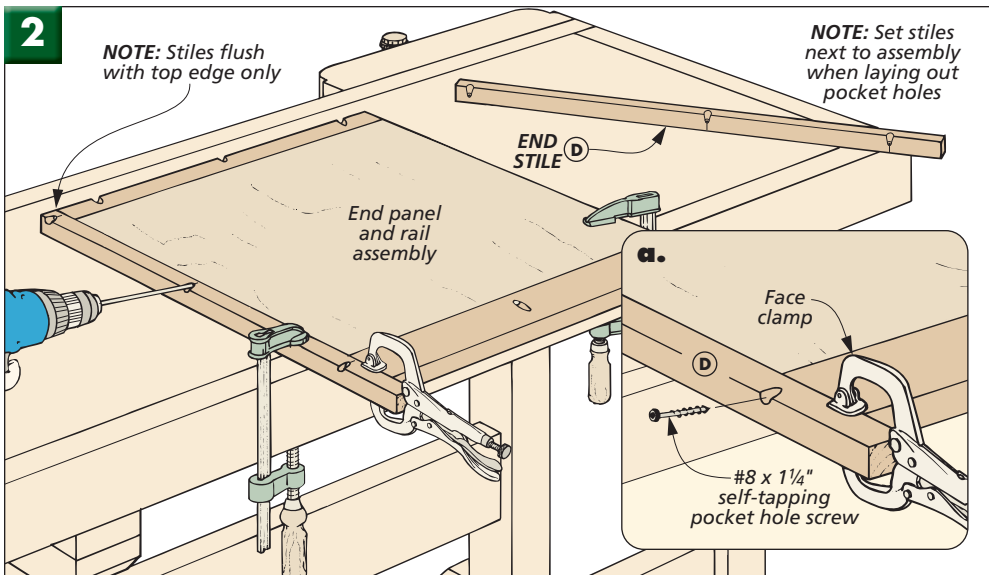

The other thing to note has to do with the use of glue. Technically, the screws should provide plenty of holding power. But to play it safe, it would be a good idea to apply glue too. However, you'll want to use the glue sparingly so you don't have a lot of excess to clean up.

To complete the frames, the two end stiles (D) are ready to be added (Fig. 2). These pieces are sized to extend below the lower rail to create short legs. It sounds simple enough, but with the stiles offset, they're not identical — the pieces are actually mirrored images of each other. So to drill the pocket holes in the right place, it's best to lay the stiles next to the assembly and mark the edges that you'll be drilling into.

TOP & BOTTOM. Now that the end assemblies are complete, they can be connected with the *case top* and *bottom* (E), as shown Figs. 3 and 4. These 3/4" plywood panels are identical, and once they've been cut to size, they're ready to be screwed to the end assemblies.

I started with the case top. After drilling the pocket holes in each end of the panel, it's screwed flush with the top edges of the end assemblies. But holding this long panel square to the ends while you're driving in the screws takes more than two hands. So I made a couple L-shaped braces to help hold the assembly square while it was being screwed

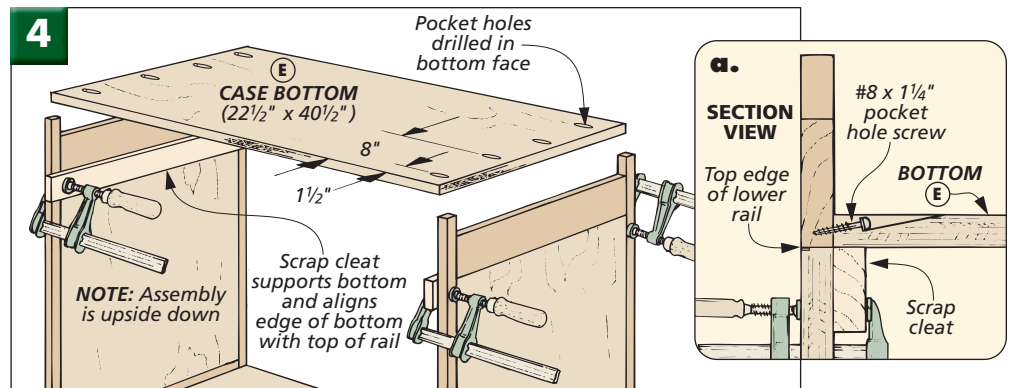
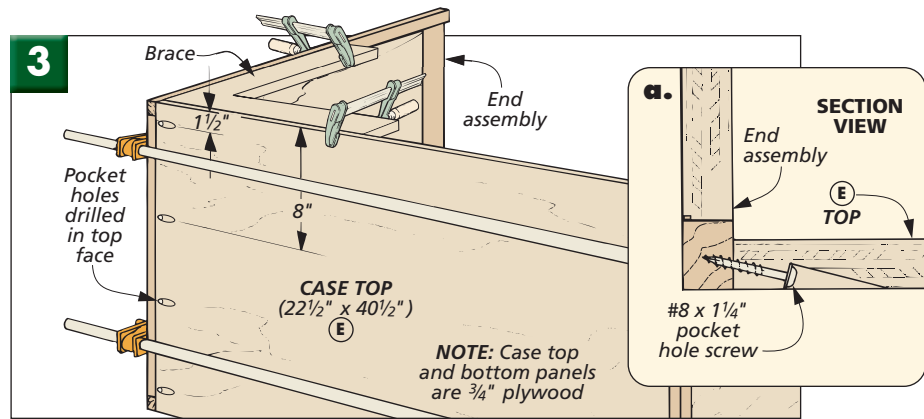

together, as shown in Fig. 3. (Here, it's okay to screw into the top face of the panel — it'll get covered with a hardwood top panel later.)

When attaching the case bottom, you'll need to flip the assembly over, as shown in Fig. 4. The idea here is to position the upper face of this panel even with the top edge of the lower end rail, as indicated in Fig. 4a. There's nothing tricky about this. All you need to do is clamp a

scrap cleat across each end and let the cleat support the panel while you screw it in place.

DIVIDER. To divide the case into two equal openings, the next piece to make is the *center divider* (F). When cutting this panel to size, note that it won't end up as deep (wide) as the top and bottom panels. As you can see in Fig. 5a, it is flush with the front of the case and stops a few inches short in back. (This space will be used to create a little trough or pocket for the cables.)

Before the plywood divider can be screwed into the case, it needs a piece of *edging* (G) to cover the plies in the front. I made this thin strip quickly and safely by ripping a 1/4"-wide strip from an oversized piece of 3/4"-thick hardwood.

The center divider is the only case piece that isn't attached with pocket hole screws. Instead, it's simply screwed to the top and bottom panels, flush with the front edges (Fig. 5a). But this panel isn't much easier to hold in place than the top and bottom panels were, so you may want to clamp some cleats to the case for support — similar to what you did with the bottom panel.

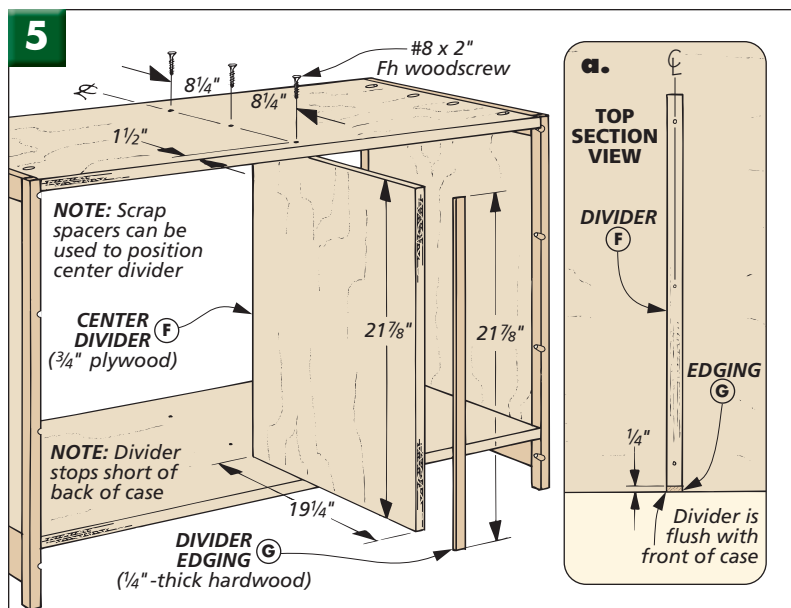

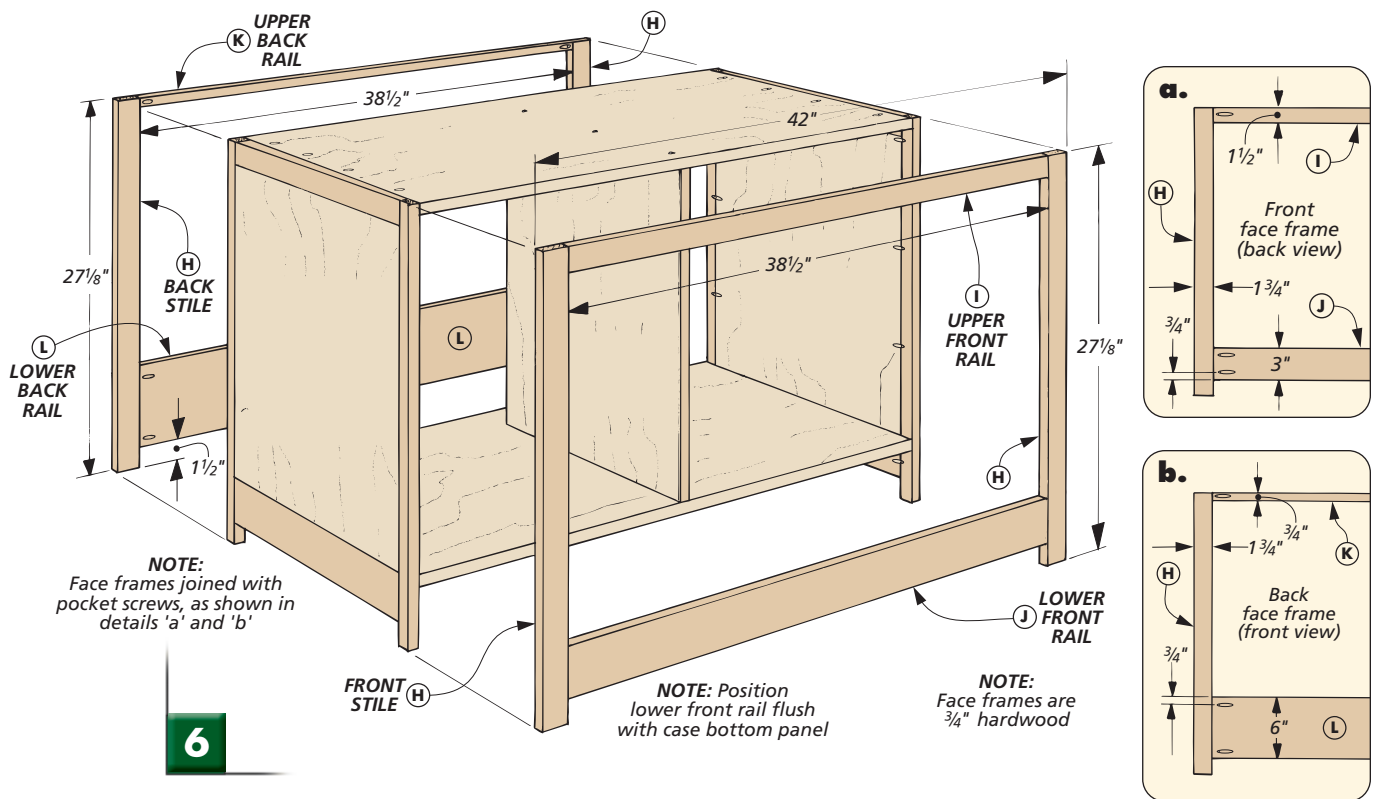

Face Frames, Shelf Standards, & Backs

Now that the main case has been assembled, it's time to add a pair of face frames, some shelf standards, and a couple of back panels.

FACE FRAMES. I started with the face frames that cover the plywood edges of the case at the front and back (Fig. 6). Typically, I'd just add a face frame to the front of a case. But the back frame here will create a shallow trough or pocket for the cables.

These two face frames aren't identical though. While the *stiles* (H) are the same, the *lower back rail* (L) is wider than the *lower front rail* (J). And to allow the back panels to fit through the opening later on, the *upper back rail* (K) is narrower than the *upper front rail* (I).

Once the face frame pieces are cut to size, they're simply screwed together. This is where pocket hole joinery really shines. These frames are quick and easy to assemble. The only thing to give extra attention to is the position of the lower front rail. You want it to end up flush with the

top face of the case bottom. So I set each stile against the case and marked the position of the bottom panel. These marks can then be used to position the lower front rail.

When the face frames are assembled, they're ready to be screwed to the case (Fig. 7). Don't worry if the frames and case don't end up perfectly flush all the way around. You can always do a little trimming later, as shown in the box at left.

SHELF STANDARDS. With the face frames in place, you can make the *shelf standards* (M) next (Fig. 8). These 3/8"-thick pieces have a series

FLUSH FACE FRAMES

When gluing a face frame to a large case, it's nearly impossible to get the edges completely flush. So I usually plan to do a little "touch-up." Most times, I'll use my block plane, setting it to take very fine shavings, see drawing. Or if there's a only slight shoulder, I'll sand it flush, using a sanding block to prevent rounding the edges.

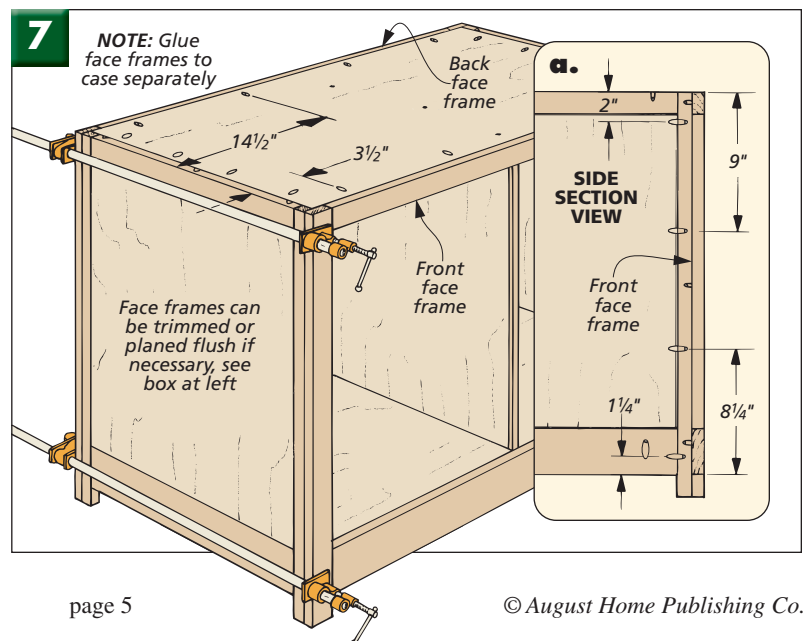
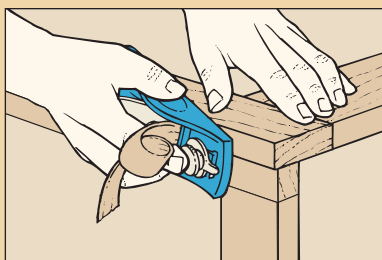

of holes for holding spoon-style shelf pins. But they do more than just support the shelves. These standards also cover the most visible pocket holes inside the case.

The shelf standards at the front of the case can simply be glued and clamped to the sides and center divider. The standards glued flush with the back of the center divider are also easy enough to install.

The trick is the back standards at the ends — they also need to align with the back of the divider. This is easy to do with a couple of scrap spacers. But then they're inset too far for clamps to reach them. So to hold them, I cut some thin, flexible strips and wedged them between the standards while the glue dried, as you can see in Fig. 9.

BACK SUPPORTS. While the glue on the standards was drying, I cut four $\frac{3}{8}$ "-thick *back supports* (N) to fit between the standards at the top and bottom of the case (Fig. 8). And since they're flush with the back edges of the standards, I used the same spacers and flexible strips when gluing them in place.

BACK PANELS. At this point, the $\frac{1}{4}$ " plywood *back panels* (O) can be cut to finished size to fit inside the case, as shown in Fig. 10. But before gluing these panels in place, I cut three access slots across the back of each (Fig. 10a). This will make it easier to feed the cables through when connecting the components, as well as let the air circulate freely. To make

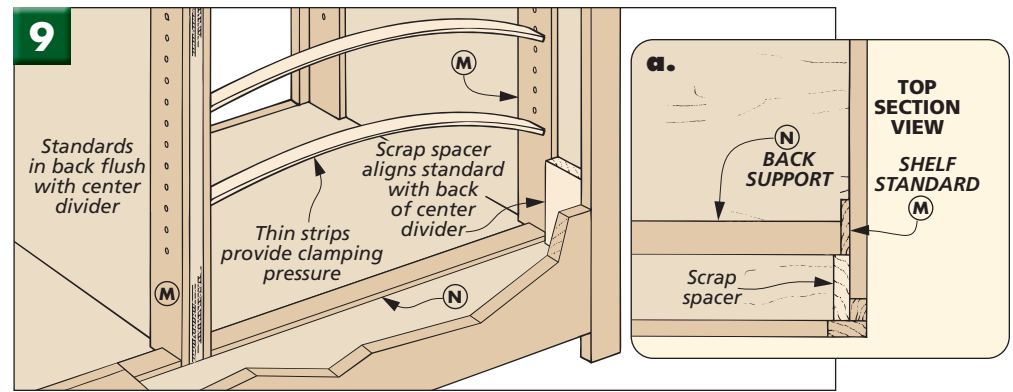
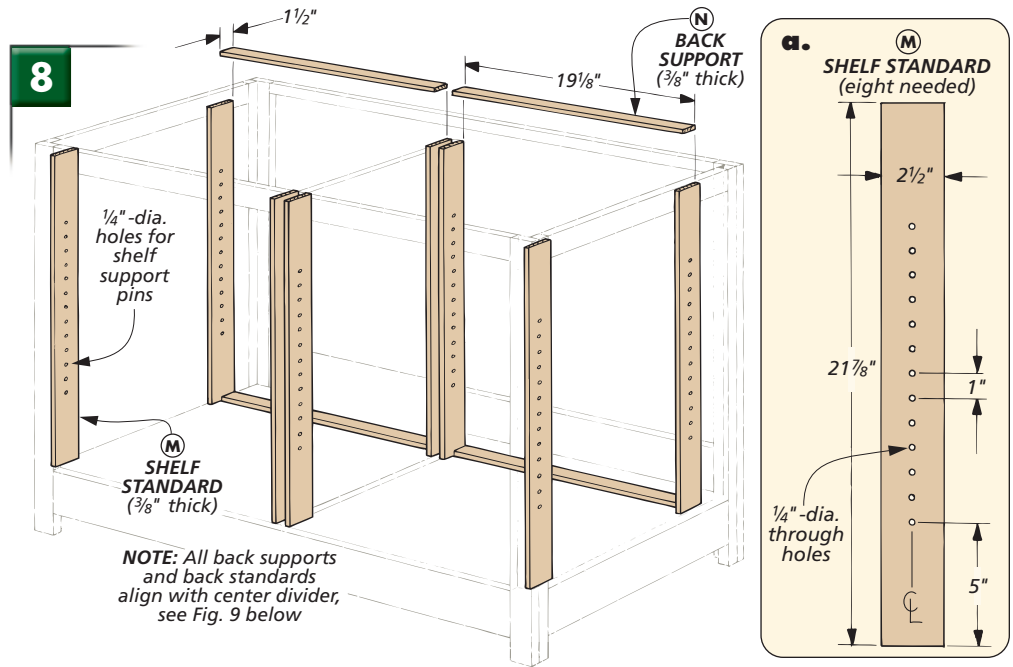

these slots, I first drilled a 1"-dia. hole at each end. Then the waste between the holes can be removed with a sabre saw, and the slots can be sanded smooth.

The back panels have to be angled to be slid in front of the back face

frame (which is why there are two back panels in the first place). And the back face frame also prevents you from being able to nail the panels in place. But a few scrap spacers will apply enough pressure to hold them while the glue dries (Fig. 10b).

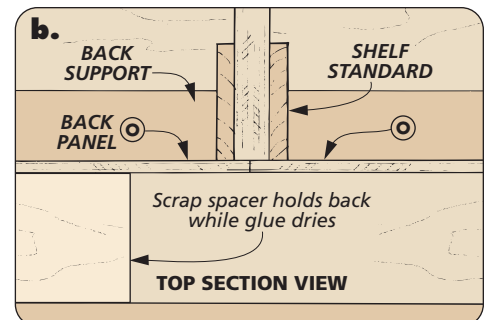
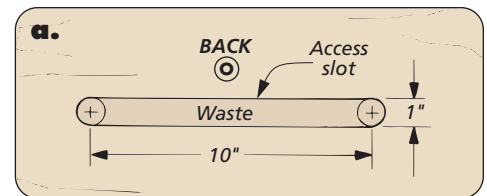
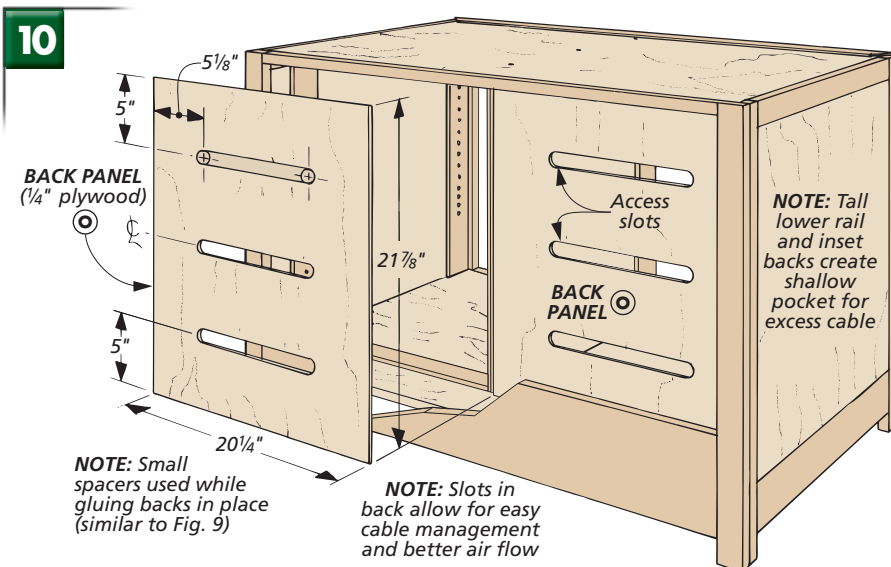

▲ The decorative shadow line on the end assemblies is repeated under the top panel. This time, it's created with thin spacers.

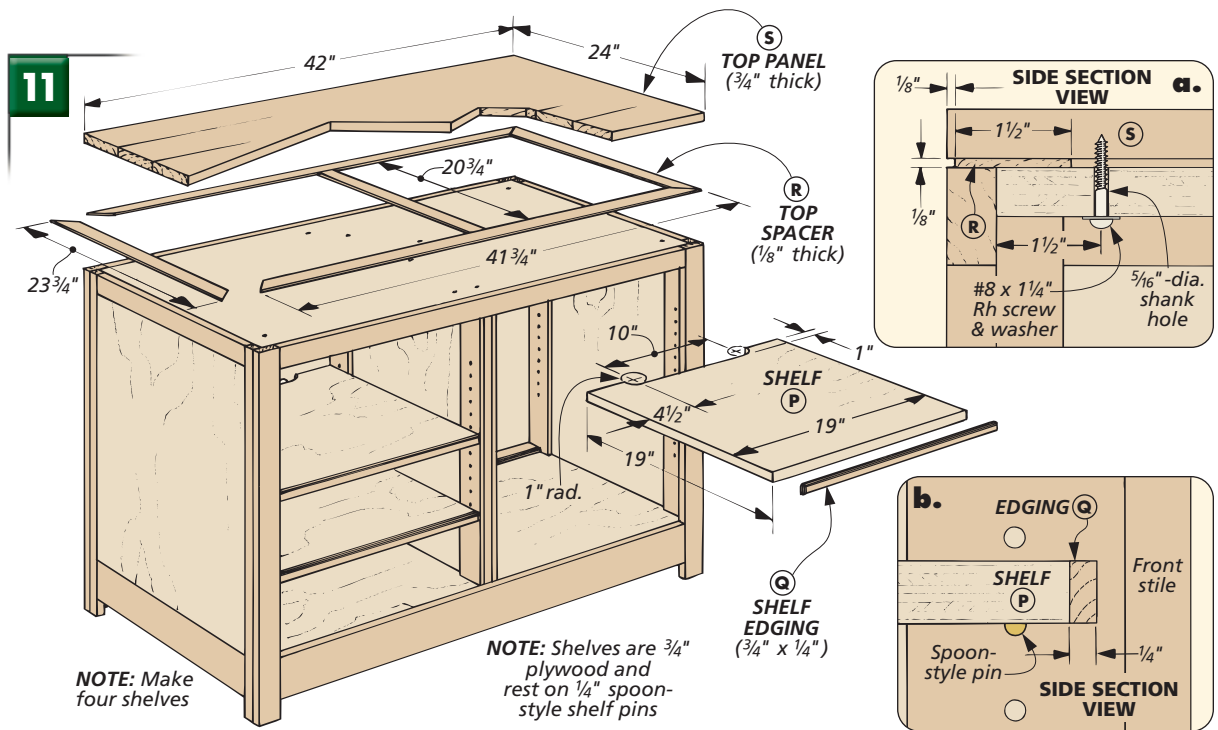

Shelves & Top

The main case of the entertainment center is just about complete. All that's left is to add some adjustable shelves and a hardwood top with some thin spacers, as in Fig. 11 above.

SHELVES. The shelves (P) are 3/4" plywood panels with hardwood edging (Q) added to the front of each. (For the edging, I ripped a 1/4"-wide strip from 3/4"-thick hardwood.)

Then to make it easier to organize the cables (and let the air circulate), I used my sabre saw to create a cutout on the back of each shelf and sanded this profile smooth.

TOP PANEL & SPACERS. Now that the shelves are in place, the last area to work on is the top of the case. As you can see in Fig. 11, there are two layers here: A large panel that rests on a layer of thin spacers.

The actual top panel (S) is glued up from 3/4"-thick hardwood. And while the glue is drying on this panel, you can begin working on the second layer that's sandwiched between the top and the case (Fig. 11). It's a thin "frame" of top spacers (R) cut from stock that's been resawn or planed down to 1/8" thick.

The spacers are mitered to length so they set 1/8" back from the edges of the case, as shown in Fig. 11a. This creates a thin shadow line similar to the one on the end panels of the case. (See margin photo at left.) Also to help support the top panel, I added a spacer at the center.

When the glue is dry, the case top can be cut to match the case and then screwed in place. I made the shank holes oversized so the top can expand and contract freely. (To find out how I finished the entertainment center, turn to page 12.) **W**

CUTTING DIAGRAM

3/4" x 7 1/4" - 96" Hard Maple (4.8 Bd. Ft.)

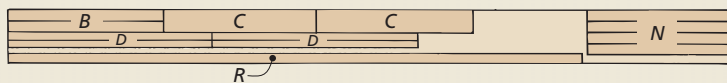

3/4" x 7 1/4" - 96" Hard Maple (4.8 Bd. Ft.)

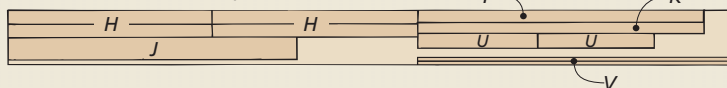

3/4" x 7 1/4" - 96" Hard Maple (4.8 Bd. Ft.)

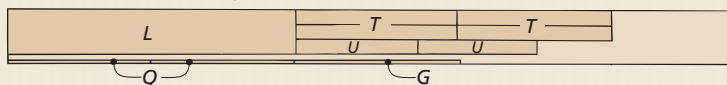

3/4" x 7 1/4" - 96" Hard Maple (Two Boards @ 4.8 Bd. Ft. Each)



3/4" x 5 1/2" - 96" Hard Maple (3.7 Bd. Ft.)

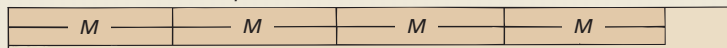

NOTE: Top spacers (R) and glass stop (V) must be resawn to get blanks needed.

3/4" - 48" x 96" Maple Plywood

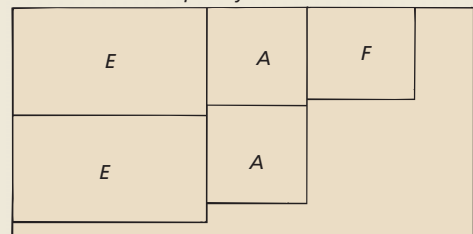

3/4" - 48" x 48" Maple Plywood

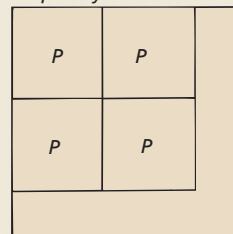

1/4" - 48" x 24" Maple Plywood

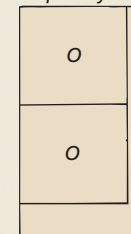

OPTIONAL DOORS

If you'd like to build a pair of inset doors for this entertainment center, you'll find they're just simple frames with glass panels, as shown in Fig. 1.

Like the face frames on the case, these doors could've been built quickly with pocket hole joinery. Plus, you can buy hardwood plugs for making the pocket holes less visible.

FRAME. But I didn't want the joinery to be visible at all, so I built the door frames with stub tenons and grooves (Figs. 1 and 1a). And when sizing the *door stiles* (T) and *rails* (U), I allowed for a $\frac{1}{16}$ " gap around the two doors, but no gap between them. (This makes the math a bit easier, and the edges of the center stiles will be trimmed later to quickly create an even $\frac{1}{16}$ " gap.)

With the stiles and rails cut to size, $\frac{3}{8}$ "-deep grooves need to be cut on the inside edges of the pieces (Fig. 1a). Then you can cut the stub tenons to fit into these grooves.

After the frames have been assembled, they're ready for the rabbet that will hold the glass (Fig. 1c). With the grooves already cut, there's not much material left to be removed, so the rabbet can be routed in a single pass (Fig. 2). But you'll still need to square up the corners with a chisel.

HINGE MORTISES. I planned to mount the doors on butt hinges. And to

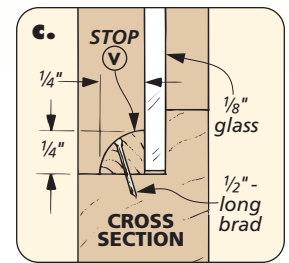
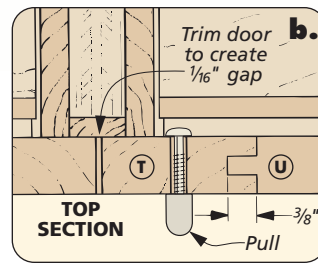
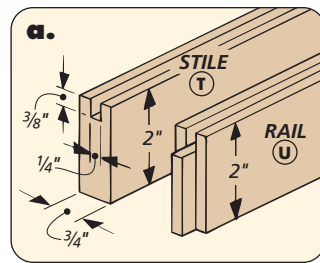
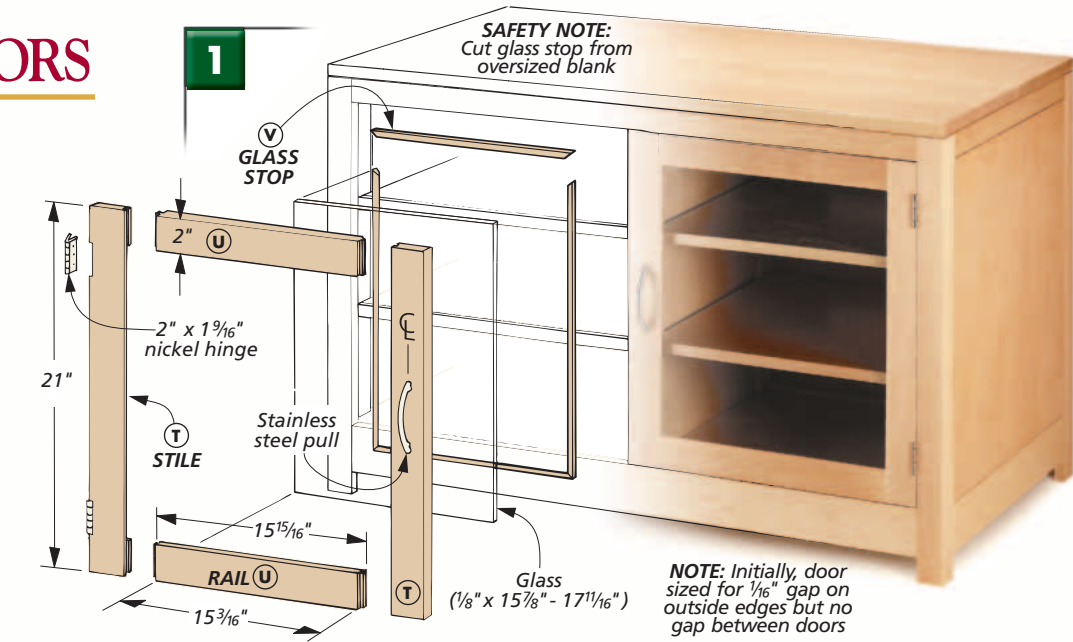

make installation easier, I cut the mortises in the door frames only, as indicated in Fig. 3a. (The hinges will be surface mounted to the case.) To do this, I used my table saw, attaching a tall auxiliary fence to the miter gauge to support the frame (Fig. 3).

GLASS. At this point, the doors are ready for the $\frac{1}{8}$ " glass panels.

Quarter-round *glass stop* (V) will hold the glass in place. (When making these tiny strips, it's best to start with oversized pieces to be safe.) Then they're mitered to length and nailed to the frame (Fig. 1c).

MOUNT DOORS. Now the doors are ready to be mounted to the case. With inset doors, the goal is to get an even gap around and between the doors. I like to concentrate on the gaps around the doors first. Then creating the gap between the doors is a simple matter of planing or sanding a little off each center stile.

HARDWARE. When the doors fit well, the last step is to add pulls to the doors and magnetic catches to the inside of the case (Figs. 1b and 4). **W**

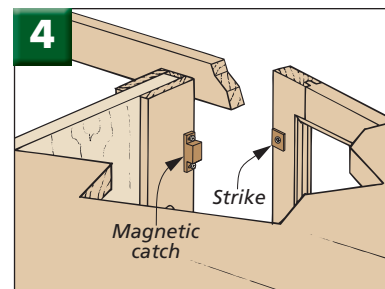
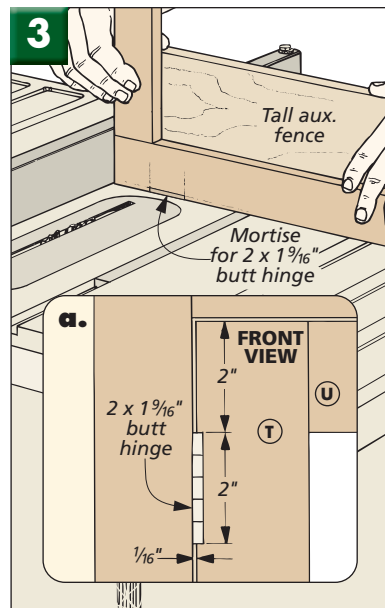
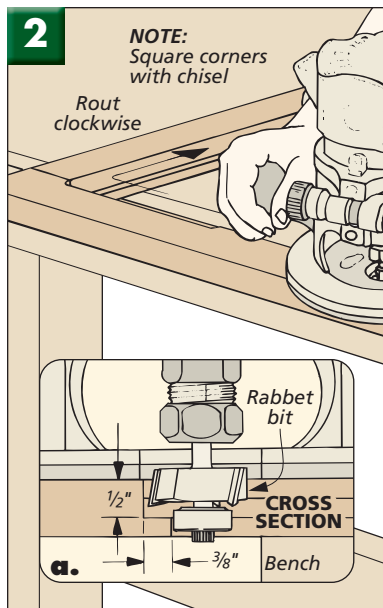

SIDE CABINET

This side cabinet is the perfect “side-kick” to the entertainment center on [page 1](#). Since its top panel is flush with the sides, the cabinet will nestle up tight on either side of the TV cabinet. And the small drawer and adjustable shelf offer quite a bit of additional space for storage.

But don't limit this cabinet to being just a component of the entertainment center. When set next to a bed or arm chair, as shown in the photos below, it also makes a great little nightstand or end table.

CONSTRUCTION NOTES. As you might expect, building this cabinet is similar to building the TV cabinet — only this one is even easier because the workpieces are smaller. However, there are some important differences to note. Instead of a vertical center divider, the side cabinet has a horizontal divider that creates a small drawer opening. Plus, the back is quite a bit different. It still has a face frame, but there's no plywood back to the cabinet and no pocket for excess cables.

END ASSEMBLIES. This small cabinet starts out just like the larger TV unit: by building two end assemblies, as shown in Fig. 1. First, the *end panel* (A) is cut to size, and the small rabbet that creates the shadow line is cut, refer to Figs. 1 and 1a on [page 3](#).

Next, the *upper* (B) and *lower end rails* (C) are attached to the



panel with pocket hole screws. Again, I drilled the stepped holes for the screws in the rails (instead of the panel) so they'd end up being hidden later. Then the two *stiles* (D) can be cut to size and attached to the assembly. And as on the larger case before, you want to get these pocket holes in the right places, so when laying them out, it's best to set the stiles next to the assembly.

CONNECTING PANELS. With the stiles in place, the two end assemblies are complete and can be connected with the $\frac{3}{4}$ " plywood *top* (E) and *bottom* (E) panels (Fig. 1). Here's where the big difference between the two cabinets begins. Instead of a vertical center divider, these side cabinets have a horizontal *divider* (E) that will support the drawer.

The divider is identical to the top and bottom panels except for one thing. I drilled $\frac{3}{4}$ "-dia. access holes in each corner so I'd be able to screw the hardwood top panel to the case later on (Figs. 1b and 4a). And while I was at it, I drilled the oversized shank holes ($\frac{5}{16}$ "") in the top (E). (They're oversized so the hardwood top will be able to expand and contract with changes in humidity.)

When connecting the end assemblies with the plywood panels, I started with the top and bottom pieces. To do this, I used braces and cleats just as I did before with TV cabinet, refer to Figs. 3 and 4 on [page 4](#).

Attaching the divider is similar to the bottom panel. It's positioned by

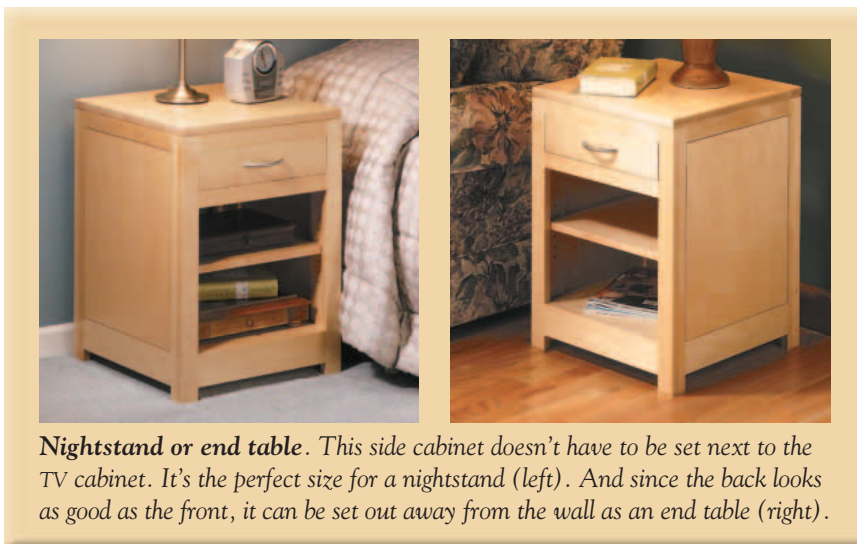

Nightstand or end table. This side cabinet doesn't have to be set next to the TV cabinet. It's the perfect size for a nightstand (left). And since the back looks as good as the front, it can be set out away from the wall as an end table (right).

a couple of cleats, but these scrap pieces can be cut to match the height of the opening between the top and divider ($4\frac{1}{4}$ "), as shown in Fig. 2. Then with the case flipped upside down, the divider and cleats simply rest on the top panel.

FACE FRAMES. Now the front and back face frames ready to be added to the case, as shown in Fig. 3. The front face frame establishes the opening for the drawer, while the one in back merely cleans up the back side so you'll be able to set the cabinet out away from a wall.

When cutting the face frame pieces to size, the four *front* and *back stiles* (F) are identical, as well as the *lower rails* (I). There are two narrow *upper front rails* (G) that create the drawer opening. And as for the *upper back rail* (H), it's $6\frac{1}{2}$ " wide and covers the entire back of the drawer opening.

Assembling the face frames here isn't much different than those made for the TV cabinet. Both lower rails should end up flush with the bottom panel, as shown in Fig. 3a. And there's the extra upper front rail that should also be flush with the divider. In both cases, you can set the stiles against the case and mark the location of the plywood panels.

TOP PANEL & SPACERS. After the face frames had been pocket-screwed to the front and back of the case, the next area I worked on was the top of the cabinet. Like the TV cabinet, there are two layers here, as you can see in Fig. 4.

First, I glued up an oversized $\frac{3}{4}$ "-thick hardwood *top panel* (K). Then while the glue was drying, I worked on the *top spacers* (J). Again, these create the shadow line under the top panel, so you'll need to plane or resaw some stock down to $\frac{1}{8}$ " thick for these pieces. Then they're simply mitered to length so they set back $\frac{1}{8}$ " from the outside edge of the cabinet.

After the top spacers have been glued in place, the top panel can be cut to finished size and then screwed down to the cabinet. (You'll need a long screwdriver to be able to tighten the woodscrews.)

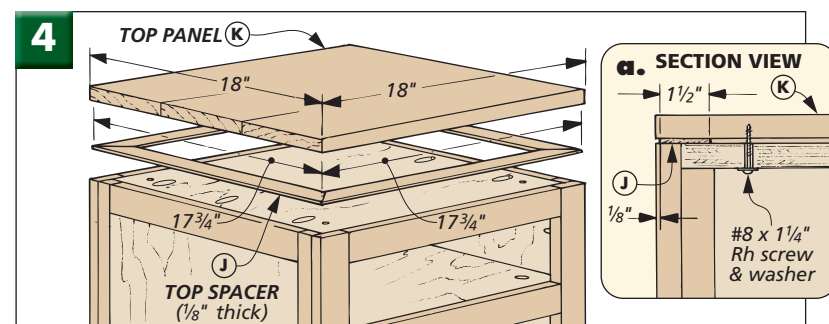
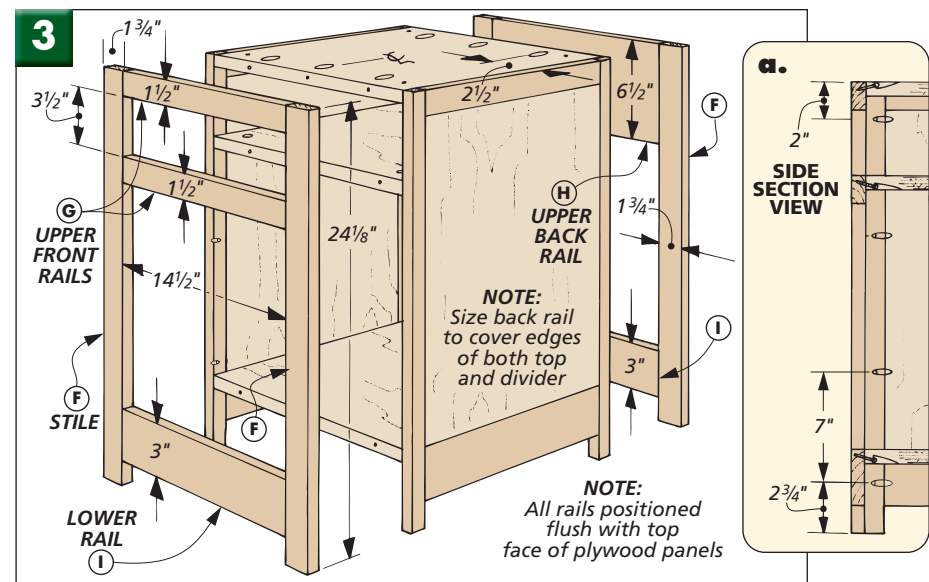
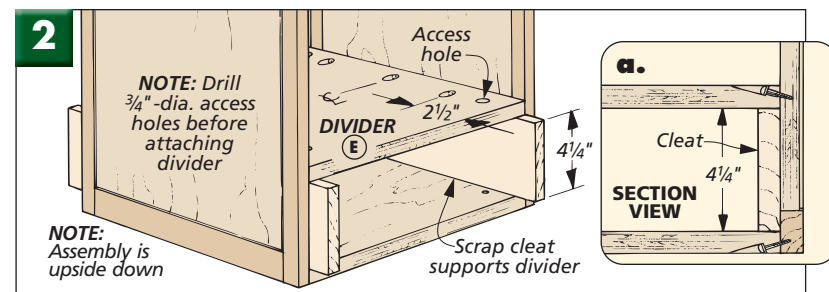
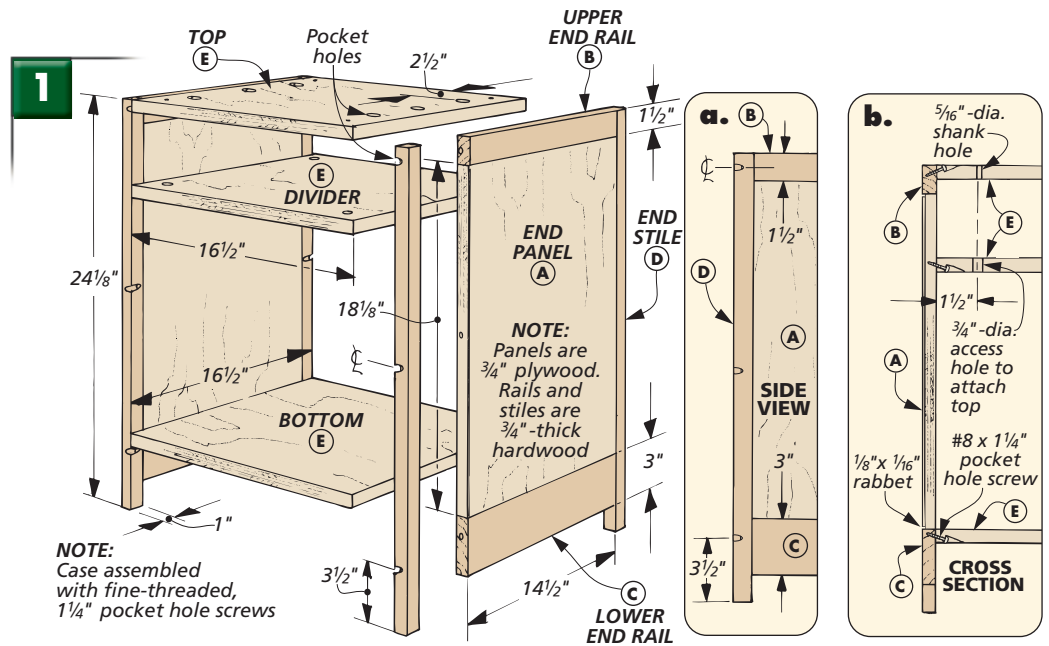

Drawer

Now that the case for the side cabinet is complete, the next thing to work on is the small drawer that fits into the opening, as shown in Fig. 5.

CUT TO SIZE. When sizing the drawer pieces, I cut the *front* and *back* (L) so there would be a $\frac{1}{16}$ " gap at the sides and top. The *side* (M) pieces are resawn or planed down to $\frac{1}{2}$ " thick and are cut to length so the drawer ends up $\frac{1}{2}$ " short of the full depth of the cabinet. (Later a stop will be added so the drawer ends up flush with the front face.)

LOCKING RABBET JOINT. To join the drawer pieces, I used a fairly simple locking rabbet joint, as described in the box below. However, if you own a router and a dovetail jig, the pieces are sized so that you could join them with half-blind dovetails.

BOTTOM. Before assembling the drawer pieces, you'll want to cut a groove near the bottom of each piece to hold a $\frac{1}{4}$ " plywood *drawer bottom* (N), as shown in Fig. 5a. Once the bottom is cut to size, the drawer can be glued together, and the pull can be added to the front.

GUIDES, KICKER, & STOP. To guide the drawer in and out of the opening, there are a few more pieces to add. First, I glued *drawer guides* (O) along the sides of the cabinet. These

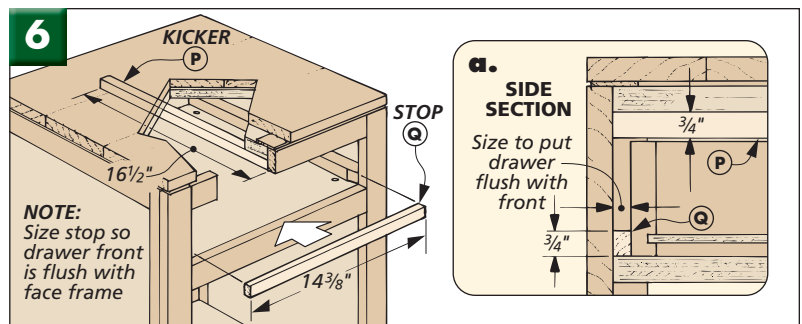
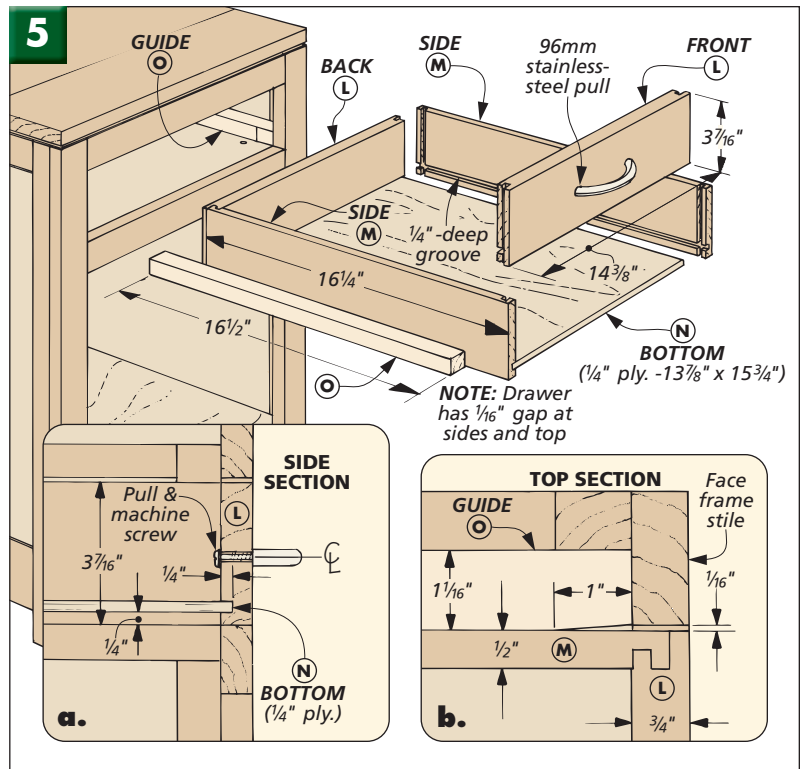

HOW TO MAKE LOCKING RABBETS

To build the drawers on the small cabinet, I used a locking rabbet joint, see photo. It's much stronger than a simple butt or rabbet joint, and it's not as difficult as cutting dovetails.

With a locking rabbet, a short tongue is cut on the front and back pieces, as in Steps 1 and 2. Then these tongues simply lock into dados cut in each side piece, see Step 3.

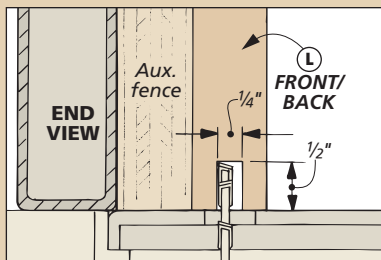

1 On the front and back pieces, cut a $\frac{1}{4}$ "-wide slot on each end. Raise the blade so the depth matches the thickness of the drawer sides ($\frac{1}{2}$ ").

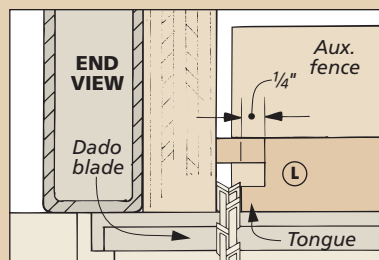

2 Next create a short tongue on the inside face of each front and back piece. Sneak up on the fence setting until the tongue is $\frac{1}{4}$ " long.

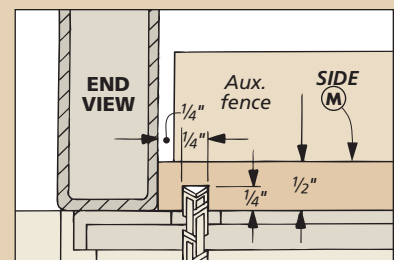

3 Finally to hold the tongue on the front and back pieces, cut $\frac{1}{4}$ " x $\frac{1}{4}$ " dados at the ends of each side piece. (Check the setup with a test piece.)

are sized to stick past the face frame stiles $\frac{1}{16}$ ", as shown in Fig. 5b. (To make it easier to "feed" the drawer into the cabinet, I tapered the front 1" of each guide with sandpaper.)

Next, to keep the drawer from tipping as it's pulled out, I glued a *kicker* (P) under the top of the case (Fig. 6). Then I added a *stop* (Q) at the back of the case. You'll want to sneak up on the width of this piece so that when the drawer stops against it, the drawer's front face will be flush with the face frame.

SHELVES & STANDARDS. For this small cabinet, I saved the shelves for last (Fig. 7). To support these panels, four *shelf standards* (R) will need to be resawn or planed down to $\frac{3}{8}$ " thick. They're basically the same as the standards in the TV cabinet (just shorter), as shown in Fig. 7.

Finally, you can cut the *shelf* (S) to size from $\frac{3}{4}$ " plywood (Fig. 7). And since this cabinet is open in the back as well as the front, I glued hardwood *edging* (T) to both the front and back edges of the shelf. **W**

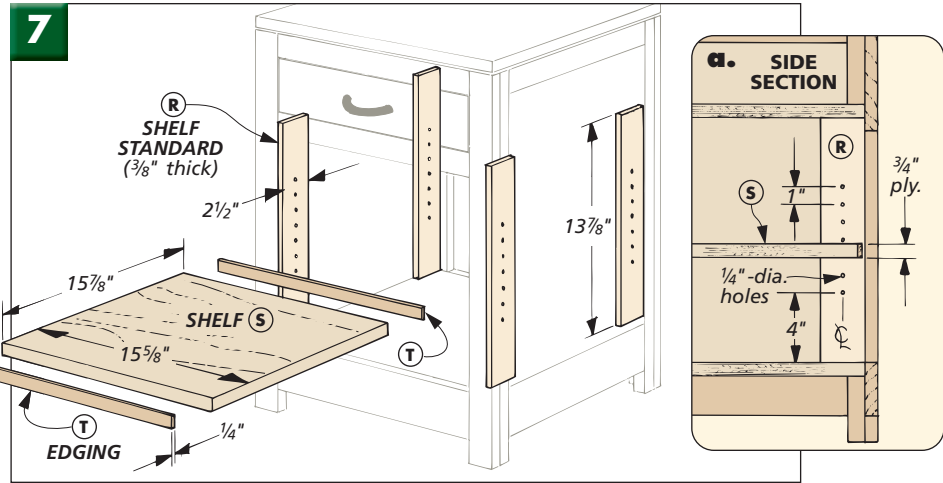

FINISHING TOUCH

When deciding on the finish for the entertainment center, I chose not to stain the wood. For one thing, the light color of maple fits well with the project's contemporary style. And besides, the color of the plywood and hardwood was a good match, and maple can be

difficult to stain evenly anyway — it often ends up looking "blotchy."

Instead, I sanded the project to 180-grit and then applied several coats of a wipe-on polyurethane. However, this would also be a great project for trying your hand at a water-based topcoat.

MATERIALS & SUPPLIES

A End Panels (2)	$\frac{3}{4}$ ply. - 14 $\frac{1}{2}$ x 18 $\frac{1}{8}$
B Upper End Rails (2)	$\frac{3}{4}$ x 1 $\frac{1}{2}$ - 14 $\frac{1}{2}$
C Lower End Rails (2)	$\frac{3}{4}$ x 3 - 14 $\frac{1}{2}$
D End Stiles (4)	$\frac{3}{4}$ x 1 - 24 $\frac{1}{8}$
E Top/Btm./Divider (3)	$\frac{3}{4}$ ply. - 16 $\frac{1}{2}$ x 16 $\frac{1}{2}$
F Front/Back Stiles (4)	$\frac{3}{4}$ x 1 $\frac{3}{4}$ - 24 $\frac{1}{8}$
G Upper Front Rails (2)	$\frac{3}{4}$ x 1 $\frac{1}{2}$ - 14 $\frac{1}{2}$
H Upper Back Rail (1)	$\frac{3}{4}$ x 6 $\frac{1}{2}$ - 14 $\frac{1}{2}$
I Front/Back Lower Rails (2)	$\frac{3}{4}$ x 3 - 14 $\frac{1}{2}$
J Top Spacers (1)	$\frac{1}{8}$ x 1 $\frac{1}{2}$ - 90 rgh.
K Top Panel (1)	$\frac{3}{4}$ x 18 - 18
L Drawer Front/Back (2)	$\frac{3}{4}$ x 3 $\frac{7}{16}$ - 14 $\frac{3}{8}$
M Drawer Sides (2)	$\frac{1}{2}$ x 3 $\frac{7}{16}$ - 16 $\frac{1}{4}$
N Drawer Bottom (1)	$\frac{1}{4}$ ply. - 13 $\frac{7}{8}$ x 15 $\frac{3}{4}$
O Drawer Guides (2)	$\frac{3}{4}$ x 1 $\frac{1}{16}$ - 16 $\frac{1}{2}$
P Drawer Kicker (1)	$\frac{3}{4}$ x $\frac{3}{4}$ - 16 $\frac{1}{2}$
Q Drawer Stop (1)	$\frac{3}{4}$ x $\frac{1}{2}$ - 14 $\frac{3}{8}$
R Shelf Standards (4)	$\frac{3}{8}$ x 2 $\frac{1}{2}$ - 13 $\frac{7}{8}$
S Shelf (1)	$\frac{3}{4}$ ply. - 15 $\frac{7}{8}$ x 15 $\frac{5}{8}$
T Shelf Edging (2)	$\frac{3}{4}$ x $\frac{1}{4}$ - 15 $\frac{5}{8}$

- (1 pkg.) $\frac{1}{4}$ " Pocket Hole Screws
- (4) #8 x $1\frac{1}{4}$ " Rh Woodscrews
- (4) #8 Flat Washers
- (1) 96mm Stainless-Steel Pull
- (4) Spoon-Style Shelf Supports

CUTTING DIAGRAM

$\frac{3}{4}$ " x 7 $\frac{1}{4}$ " - 96" Hard Maple (4.8 Bd. Ft.)



$\frac{3}{4}$ " x 7 $\frac{1}{4}$ " - 96" Hard Maple (4.8 Bd. Ft.)

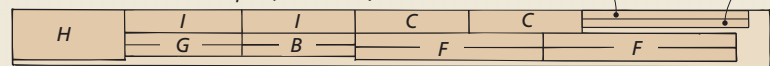

$\frac{3}{4}$ " x 5 $\frac{1}{2}$ " - 96" Hard Maple (3.7 Bd. Ft.)

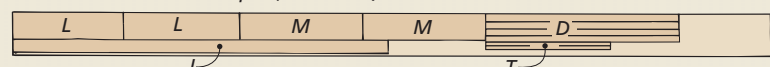

$\frac{3}{4}$ " - 48" x 48" Maple Plywood

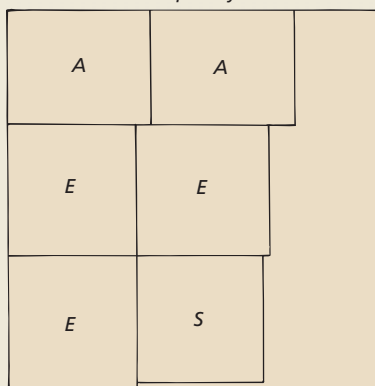

$\frac{1}{4}$ " - 24" x 24" Maple Plywood

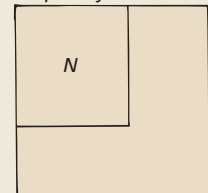

NOTE:
Top spacers (J) must be resawn to get blanks needed.